

User Manual

Wireless ANC Headphones with Charging Stand

Aria Podio

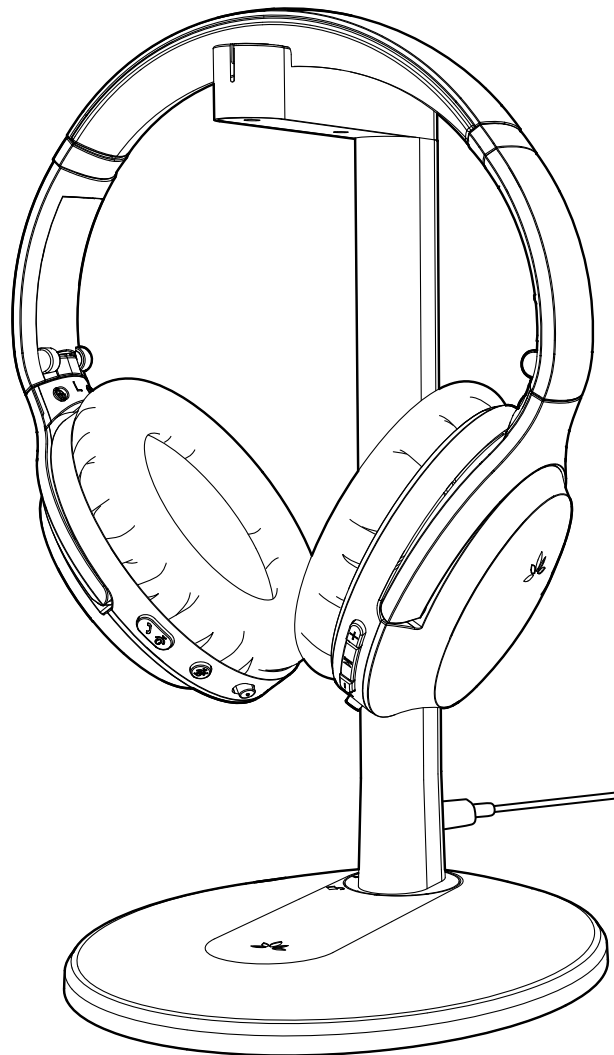

What's in the box?	1
Product Overview	1
Basic Operation	1
LED indications	2
Bluetooth Pairing	2
Reconnection	2
Using the AUX Input	3
Charging	3
Clear pairing history	3
Troubleshooting	3

What's in the box?

1. AS90T wireless headphones x 1
2. Charging stand x 1
3. Detachable boom microphone x 1
4. Hard travel case x 1
5. USB charging cable x 1
6. Audio cable x 1

Product Overview

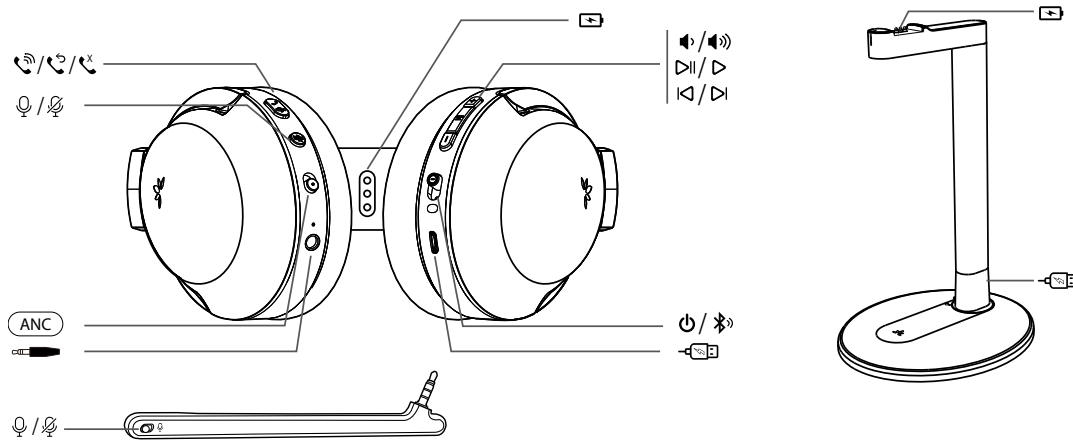

Basic Operation

<p>Power ON – </p> <p>Power OFF – </p> <p>Pairing Mode – </p>	<p>Slide the power switch to middle position</p> <p>Slide the power switch to </p> <p>Slide the power switch to and hold for 3s till LED blinks RED & BLUE alternately</p>
<p>Play / Pause music – Press </p> <p>Volume up / down – Press / </p> <p>Next / Previous track – Hold / for 2s</p>	<p>Answer / End a call – Press </p> <p>Last number redial – Press twice</p> <p>Reject a call – Hold 2s during an incoming call</p> <p>Activate / Deactivate Voice Assistant – Press </p>
<p>Activate ANC – (Power ON status)</p> <p>Deactivate ANC – </p>	<p>Headset without boom mic – Press once to mute / unmute</p> <p>with Boom Mic – Mute On / Mute Off </p>
<p>Activate Voice Prompts - Hold BOTH and for 1s</p> <p>Deactivate Voice Prompts - Hold BOTH and for 1s</p>	
<p>Clear paired history - Hold BOTH and for 5s till LED blinks PINK for 2s, then the headphones enter into PAIRING MODE automatically</p>	

LED indications

Working Status	LED indicator
Pairing Mode	Blinks BLUE & RED alternately
Reconnecting	Blinks BLUE once every 1s
Disconnected	Blinks BLUE once every 2s
Connected with SBC Codec	Blinks BLUE once every 5s
Connected with FS Codec	Remains BLUE
Connected with AptX Codec	Blinks WHITE once every 5s
Connected with AptX-LL Codec	Blinks WHITE twice every 5s
Connected with AptX-HD Codec	Blinks WHITE three times every 5s
Low Battery	Blinks RED

Bluetooth Pairing

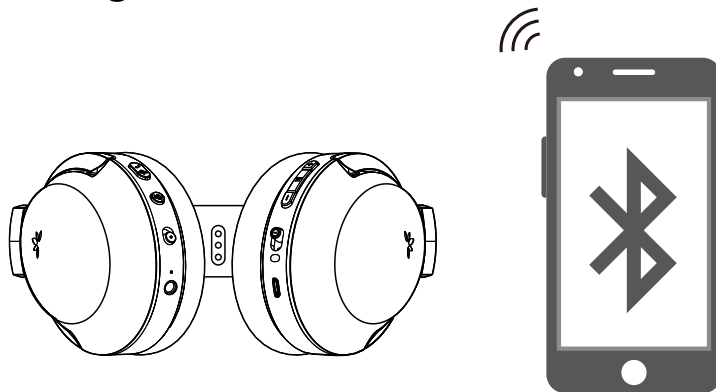

Put the headphones into Pairing Mode (On 1st use, it will enter PAIRING MODE automatically once turned on.)

Pair to mobile device

Set the headphones into Pairing Mode as above. Activate Bluetooth on your phone and set it to search for new devices. Select "Avantree AS90T", once successfully paired you'll hear "connected".

To add another cell phone

Connect with the FIRST phone as above, then turn off the headphones.

Connect headphones with SECOND phone as above. Tap and select "Avantree AS90T" on the FIRST phone

Now, Avantree Aria Podio connected with TWO phones simultaneously.

Reconnection

Normally, when the next time you turn on Avantree Aria Podio, it will automatically reconnect the last paired device.

Alternatively, Slide the power switch to [X] once  then release to enter into its Reconnection Mode.

Using the AUX Input

• Use the supplied 3.5mm audio cable to connect to a non-Bluetooth device.

Note: If you wish to use the ANC function in wired mode, please turn on the headphones first.

Charging

When the LED flashes **RED** once every 60 seconds, please recharge your headphones.

Please place the headphones onto the charging dock or plug it into a USB wall charger (DC 5V/0.5-2A) using the included micro USB cable. Normally it will take about 2 hours to fully charge. Place the headphones onto the charging dock, the LED indicator on the stand will stay solid **WHITE** while charging and turn **GREEN** when charging is complete. While charging, the headphones' LED will turn **RED** and will turn off once charging is complete.

To assemble the hanger onto the base – please match the arrow on the hanger support with the **UNLOCK** position

on the base. Insert and twist clockwise until it clicks into position.

Note: To avoid damage to headphones, please **DO NOT** charge the headphones using both the desktop charging stand and the micro USB cable at the same time.

Clear pairing history

If you have issues with the audio stream skipping or cutting out when using Avantree Aria Podio (AS90T), please try to clear pairing history as following:

Firstly, turn on the headset (Non-calling Status), then Hold BOTH [⊕] and [⊖] for 5s till LED blinks **PINK** for 2s, then the headphones enter into **PAIRING MODE** automatically

Troubleshooting

<https://avantree.com/catalogsearch/result?q=Aria+Podio>

1. No sound with PC?

- 1) Under Playback Devices select the Avantree AS90T as the default playback device
- 2) When using AS90T to make VOIP calls from an app, please select the AS90T, Hands-Free for Microphone and Speaker device

2. No sound using a Bluetooth transmitter to watch TV?

- 1) Ensure the Bluetooth transmitter and headphones are connected properly
- 2) Check that your audio OUTPUT is functioning properly
 - AUX & RCA (red and white) outputs on TV – test audio with any wired headphone

- OPTICAL output on TV – set your TV audio format to “PCM/LPCM” or turns off Dolby/DTS

3) Change your TV audio out device setting to External speakers/Headset

3. Headphones do not pair with Bluetooth device

- 1) Ensure the AS90T is in Pairing mode – LED will flash BLUE and RED alternately.
- 2) For Bluetooth transmitter, ensure the transmitter is in Pairing mode – please refer to user manual.
- 3) For mobile phones, tablets and PCs:
 - Turn the Bluetooth off then on again.
 - Delete/forget the “Avantree AS90T” from your device’s Bluetooth list and then try to pair again
 - Clear the headphone’s pairing history, and pair again